

# Screw clamps v-klema type HM, HS steel single

HM 6-50

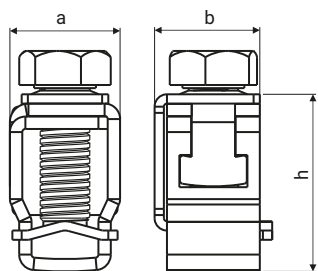

HS 10-95

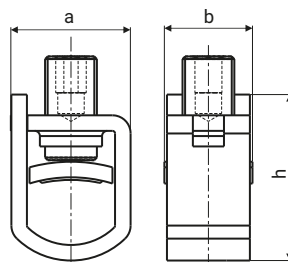

HS 6-50

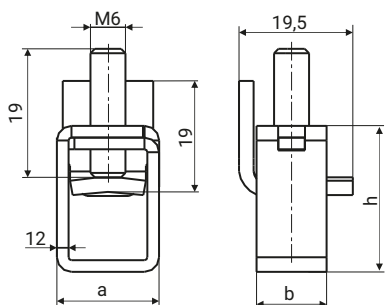

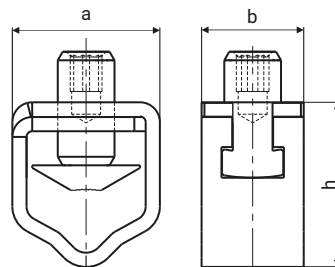

HM 10-95/A  
HM 10-95/C

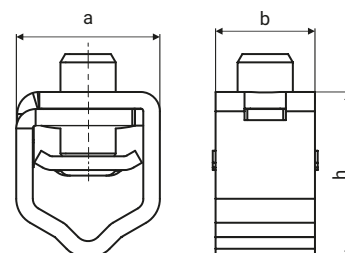

HM 25-150/A  
HM 25-150/B

HM 10-95/B



 **sm** - multiwire sector shaped conductor (flexible)

 **rm** - round multiwire conductor (flexible)

 **se** - sector shaped conductor (rigid)

 **re** - round conductor (rigid)

DETAIL	CROSS-SECTION [mm <sup>2</sup> ]				NOMINAL CROSS-SECTION [mm <sup>2</sup> ]	MAX TIGHTENING TORQUE [Nm]	DIMENSIONS		
	sm	se	rm	re			a	b	h
HM 6-50	25-50	25-50	6-50	6-50	50	8	18	16	30
HM 10-95/A	25-95	20-120	10-70	10-70	95	15	26	18	30
HM 10-95/B	25-95	20-120	10-70	10-70	95	15	26	18	30
HM 10-95/C	25-95	20-120	10-70	10-70	95	15	26	18	30
HM 25-150/A	25-120	35-150	25-120	35-120	95	25	26	18	31,5
HM 25-150/B	25-120	35-150	25-120	35-120	95	25	26	18	31,5
HS 6-50	-	-	6-50	6-50	50	6	17,5	12	25
HS 10-95	25-95	25-95	10-95	10-70	95	15	23	16	32

	HM 6-50	HS 6-50	HS 10-95	HM 10-95/A	HM 10-95/B	HM 10-95/C	HM 25-150/A	HM 25-150/B
<b>Housing</b>	Spring steel zinc-plated		Stainless steel		Spring steel zinc-plated	Spring steel zinc-plated	Stainless steel	Steel zinc-plated
<b>Clamp</b>	Spring steel zinc-plated		Brass tin-plated		Spring steel zinc-plated	Brass tin-plated	Brass tin-plated	Brass tin-plated
<b>Screw</b>	Steel zinc-plated		Stainless steel		Steel zinc-plated	Steel zinc-plated	Stainless steel	Steel zinc-plated

\* Screw clamps have safety sign 'B' WG PN-EN 60947-7-1, (IEC 60947-7-1)