

3.ST116.001

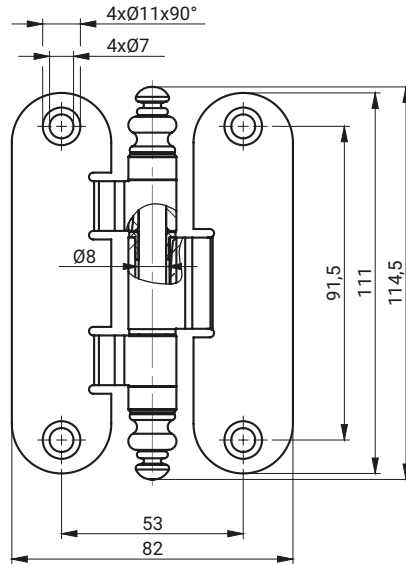

3.ST116.002

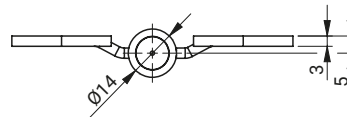
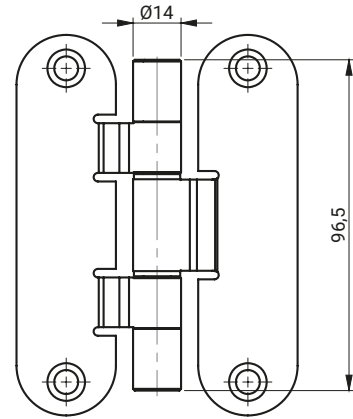

A - tulejki z tworzywa sztucznego

NR KATALOGOWY	ELEMENTY SKŁADOWE	MATERIAŁ	WYKOŃCZENIE
3.ST116.001.01	Uchwyt, Stopa, Zaślepki	Stal	Ocynk + lakier
	Sworzeń		Ocynk
3.ST116.001.02	Uchwyt, Stopa, Zaślepki		Mosiądzowany + lakier
	Sworzeń		Ocynk
3.ST116.002.01	Uchwyt, Stopa, Zaślepki		Ocynk + lakier
	Sworzeń		Ocynk
3.ST116.002.02	Uchwyt, Stopa, Zaślepki		Mosiądzowany + lakier
	Sworzeń		Ocynk