

NR KATALOGOWY	ELEMENTY SKŁADOWE	MATERIAŁ	WYKOŃCZENIE [C]	
			Nikiel	RAL9005
3.517.001	Uchwyt, Stopa	ZAMAK 5	02	04
	Sworzeń	Stal ocynkowana	-	-

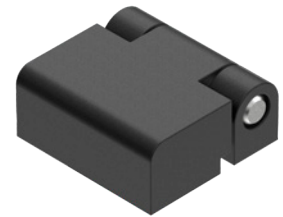

NR KATALOGOWY	ELEMENTY SKŁADOWE	MATERIAŁ	WYKOŃCZENIE [C]	
			Nikiel	RAL9005
3.517.002	Uchwyt, Stopa	ZAMAK 5	02	04
	Sworzeń	Stal ocynkowana	-	-

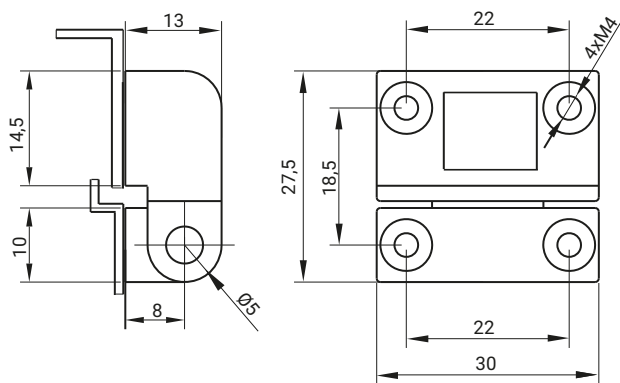
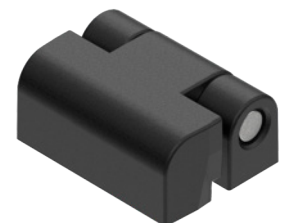
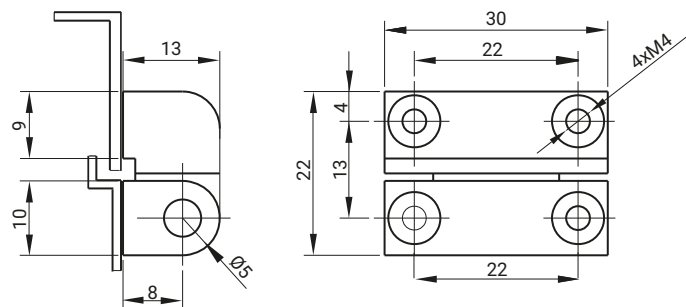

NR KATALOGOWY	ELEMENTY SKŁADOWE	MATERIAŁ	WYKOŃCZENIE [C]	
			Nikiel	RAL9005
3.517.003	Uchwyt, Stopa	ZAMAK 5	02	04
	Sworzeń	Stal ocynkowana	-	-

Jak zamawiać:

Nr katalogowy

Wykończenie

