

H	CAM 1 PKT	CAM 2 PKT	CAM 3 PKT
	GH=12,5		
2	601	625	631
3,5	602		632
6,5	603		633
9,5	604		634
12,5	605		635
15,5	606		636
18,5	607		637
21,5	608		638

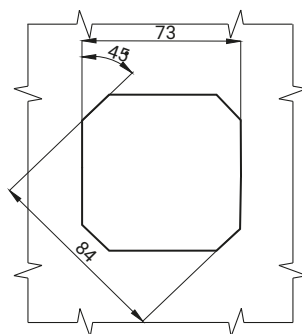

Cut out

Tab. The cam codes to order

CATALOGUE NO.	COMPONENTS	MATERIAL	FINISH [C]	
			Chrome	RAL 9005
2.608.001	Housing	Polyamide	-	07
	Handle	ZAMAK 5	01	-
	Cam	Steel zinc plated	-	-

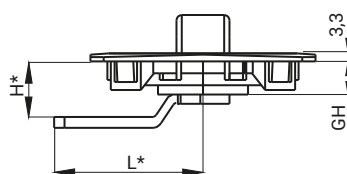
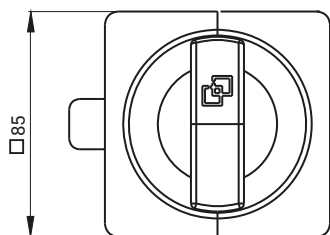

H	CAM 1 PKT	CAM 2 PKT	CAM 3 PKT
	GH=12,5		
2	601	625	631
3,5	602		632
6,5	603		633
9,5	604		634
12,5	605		635
15,5	606		636
18,5	607		637
21,5	608		638

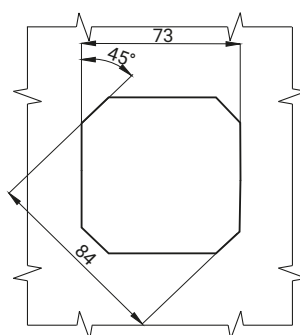

Cut out

Tab. The cam codes to order

CATALOGUE NO.	COMPONENTS	MATERIAL	FINISH [C]	
			Chrome	RAL 9005
2.609.001	Housing	Polyamide	-	07
	Handle	ZAMAK 5	01	-
	Cam	Steel zinc plated	-	-

* possibility to order in another dimension

How to order:

Type of lock

Type of cam

Finish

