

Cut out

CATALOGUE NO.	COMPONENTS	MATERIAL	FINISH [C]	
			RAL 9005	
2.603.001	Housing, insert	Polyamide	07	

How to order:

Type of lock
Finish

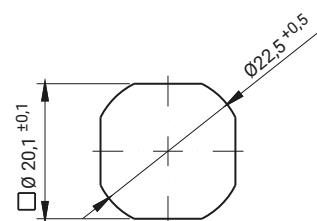
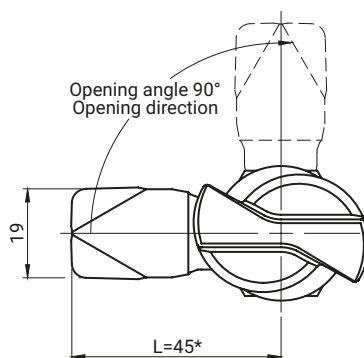
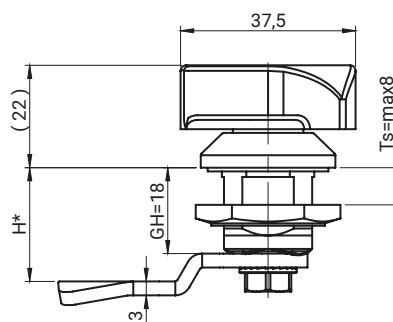
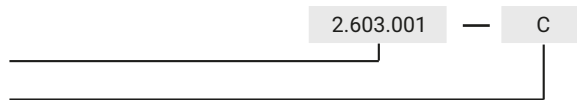

Cut out

CATALOGUE NO.	COMPONENTS	MATERIAL	FINISH [C]	
			RAL 9005	RAL 7035
M22D-M	Housing, insert	Polyamide	07	08
	Cam	Steel zinc plated	-	-

How to order:

Type of lock
The height of cam H
Finish [C]

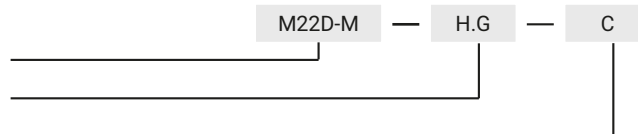

where:

H - the cam unbending dimension

G - cam group

Ts - thickness door

* Possibility to order in a different dimension

The lock is fitted with cams from the group: 15, 16, 19, 21, 35, 36, JK1-10018, JK2-10018, J-6000.01, J-6000.02, JK-1610.01, JZ-001 (pg. 1C-12 to 1C-23)