

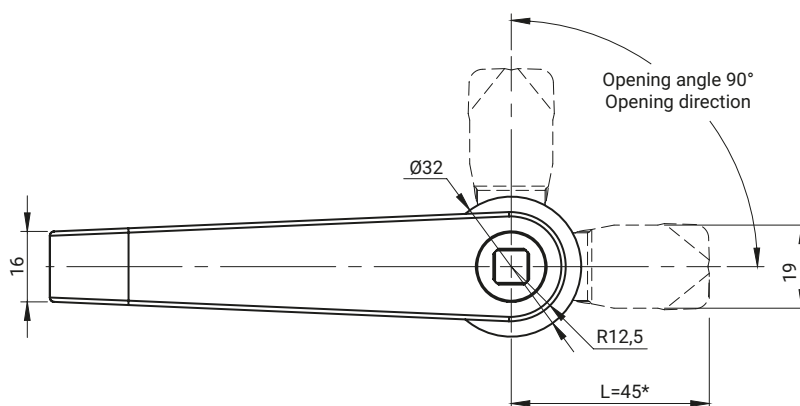

NEW

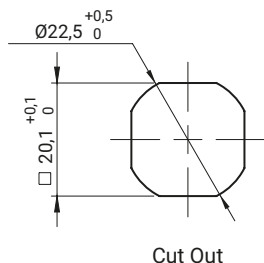
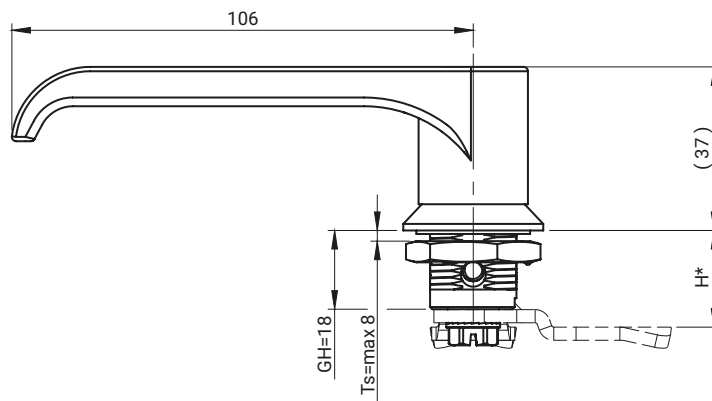

Lock with a torsion spring based mechanism locking the rotation of the handle (rotation of the handle possible only after turning the key, after its removal the lock automatically returns to the original-locked position).

CATALOGUE NO.	FINISH [C]	
2.L18.302	RAL9005	
2.L18.301	Chrome	
COMPONENTS	MATERIAL	
Housing, Handle	ZAMAK 5	
Insert	Steel	
INSERT [X]	FINISH [C]	
KW8	Chrome	RAL 9005
	01	04

How to order:

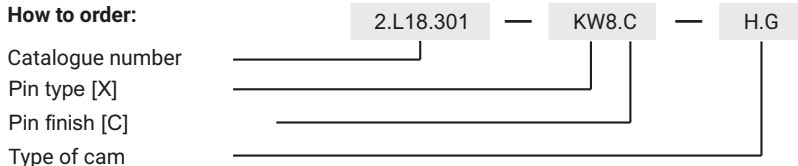

where:
H.G.:
H - height locking
G - cams range
Ts - thickness door

The lock is fitted with cams from the group: 12, 14, 17, 17A, 18, 32, 34, JK1-16018, JK2-16018, J-6000.03, J-6000.04, JK-1610.01, JZ-002 (pg. 1C-10 to 1C-23)

* possibility to make in another dimension