

Kierunek zwalniania rygla

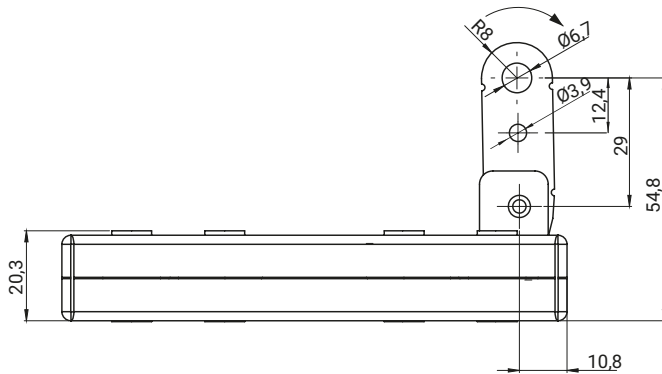

Maksymalna średnica pręta do ryglowania wynosi 17mm

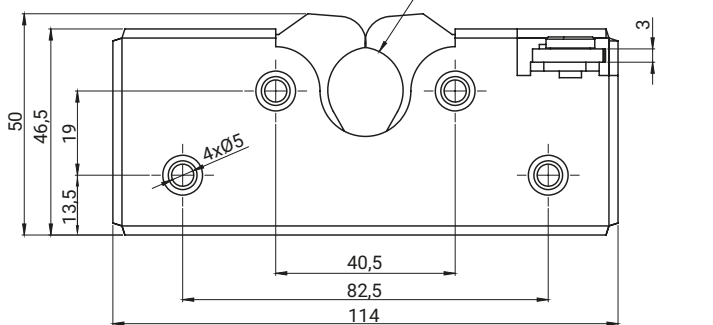

NR KATALOGOWY	ELEMENTY SKŁADOWE	MATERIAŁ
2.507.001	Obudowa	Stal ocynkowana
	Rygiel	Stal oksydowana

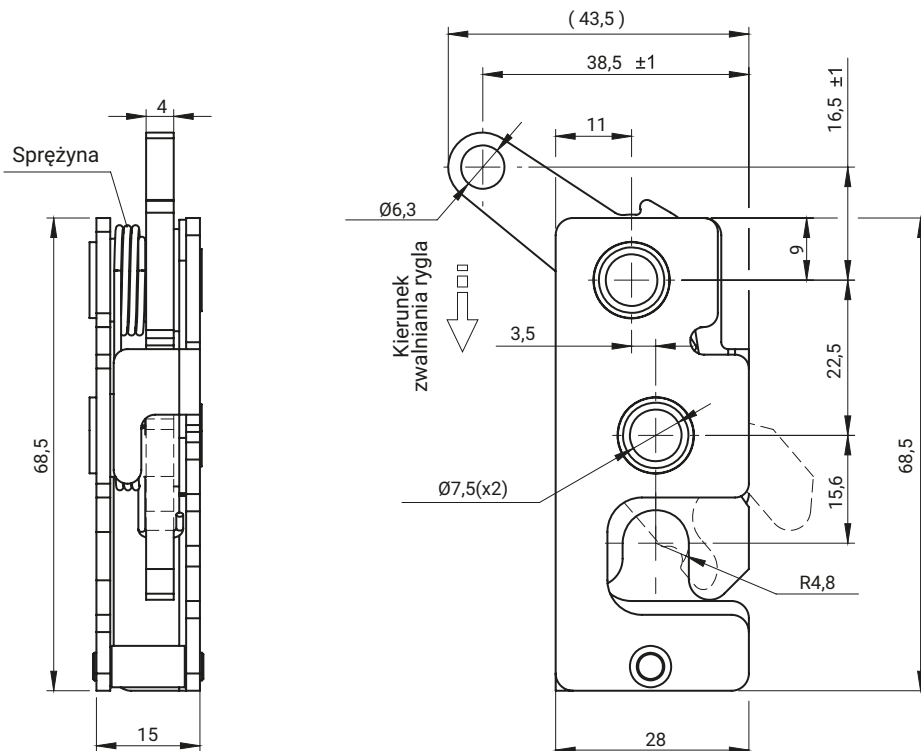

dla wersji ze stali nierdzewnej

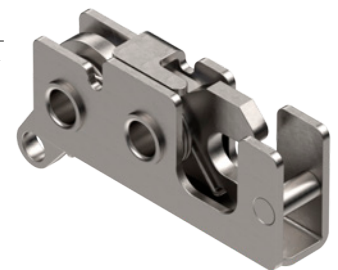

NR KATALOGOWY	ELEMENTY SKŁADOWE	MATERIAŁ
2.517	Obudowa, Rygiel	Stal nierdzewna