

# Swinghandle

## RS130, RS135, RS140, RS145

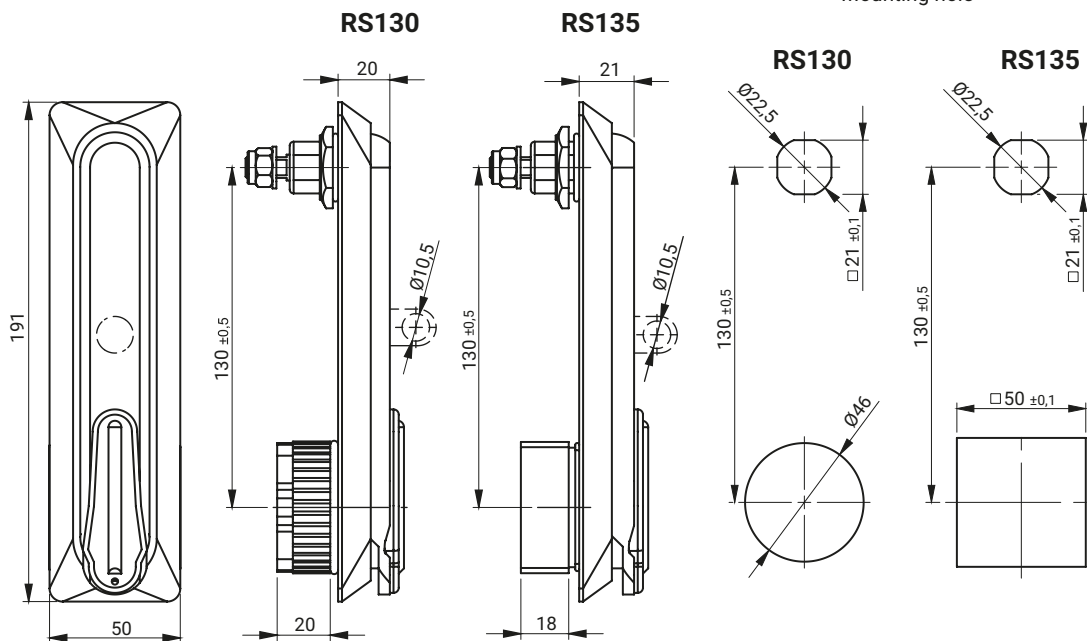

TYPE OF LOCK	COMPONENTS	MATERIAL
RS130, RS130/U	Housing	Polyamide - PA6 GF30
RS135, RS135/U		
MATERIAL AND FINISH [C]		
ZAMAK 5	POLYAMIDE PA6 GF30	
RAL9005	RAL9005	
04	07	

**How to order:**

Type of lock

Material handle, colour

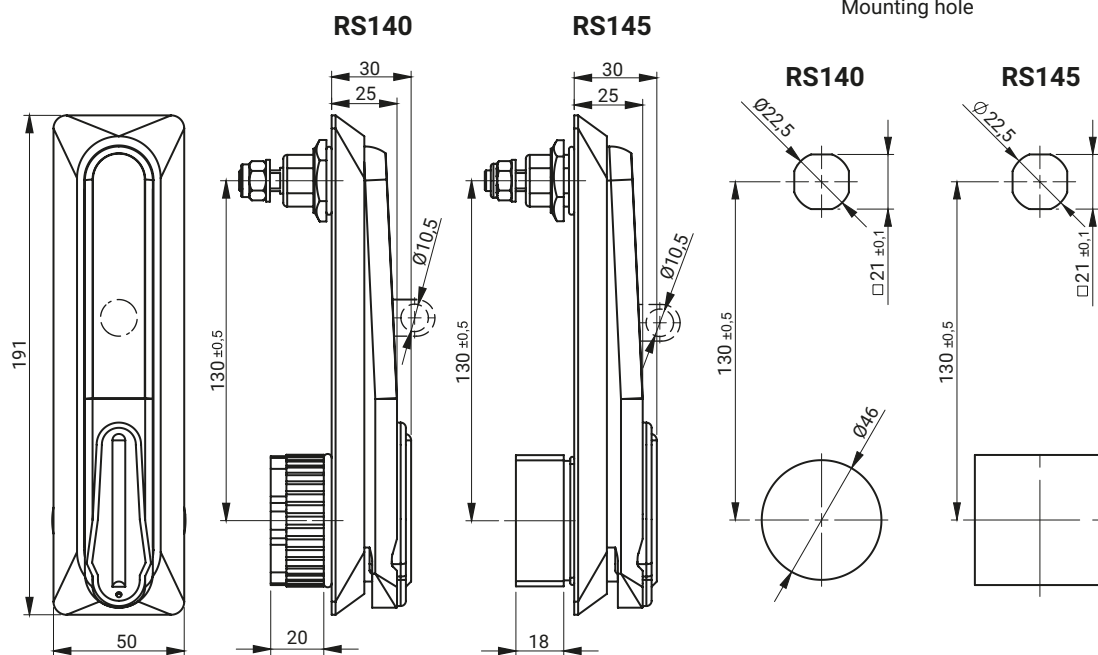
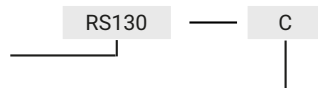

TYPE OF LOCK	COMPONENTS	MATERIAL	FINISH [C]
			RS140, RS140/U
RS145, RS145/U	Handle	ZAMAK 5	04